

1-31-2010

THE GLOBAL CRISIS IMPACT ON INDONESIA REGIONAL ECONOMY

Andry Prasmuko

Donni Fajar Anugrah

Follow this and additional works at: <https://bulletin.bmeb-bi.org/bmeb>

Recommended Citation

Prasmuko, Andry and Anugrah, Donni Fajar (2010) "THE GLOBAL CRISIS IMPACT ON INDONESIA REGIONAL ECONOMY," *Bulletin of Monetary Economics and Banking*: Vol. 12: No. 3, Article 1.

DOI: <https://doi.org/10.21098/bemp.v12i3.376>

Available at: <https://bulletin.bmeb-bi.org/bmeb/vol12/iss3/1>

This Article is brought to you for free and open access by Bulletin of Monetary Economics and Banking. It has been accepted for inclusion in Bulletin of Monetary Economics and Banking by an authorized editor of Bulletin of Monetary Economics and Banking. For more information, please contact bmebjournal@gmail.com.

THE GLOBAL CRISIS IMPACT ON INDONESIA REGIONAL ECONOMY

Andry Prasmuko
*Donni Fajar Anugrah*¹

Abstract

This paper analyzes the impact of global financial crisis to the Indonesia's economy by using the simultaneous macro model approach. The analysis and the simulation show that the impact of the global financial crisis is dominantly distributed through the trade line, which decreases the regional output. Among the aggregate demand components, the movement of exchange rate has major effect on the exports and imports, whereas on consumption and investment, it gives relatively small effect. The impact of external shock, which causes the depreciation of Rupiah, is relatively small to the increase of inflation.

JEL classification : C32, E44

Keywords : Financial crisis, simultaneous model, Indonesia, IRIO.

¹ Andry Prasmuko (andry@bi.go.id) and Donni Fajar Anugrah (donni@bi.go.id) are researcher on BRE-DKM Bank Indonesia. The views on this paper are solely of the authors and not necessarily represent the views of Bank Indonesia. We thank to Dr. Iskandar Simorangkir, Meily Ika Permata dan Yanfitri, the referee and others on their valuable comment on finishing this paper.

I. INTRODUCTION

The global financial crisis, as the impact of the subprime mortgage tragedy in America, encourages the decrease of economy in several advanced countries. The crisis spread through the financial and trade lines. In the financial line, the crisis encourages the increase of fund that will be used for unpredictable activities (precautionary saving) and then followed by the decrease of asset price that causes the lack of the customer sentiment so that they withdraw their expenses. Moreover, both collectively cause the contraction of domestic economy activities that finally decrease the Gross Domestic Product (GDP). In addition, the global financial crisis may indirectly influence the sentiment of investors to immediately withdraw their investments in financial sector, which surely affects the decrease of GDP.

The crisis causes the economy runs slow, particularly in advanced countries. It also leads to the decrease of demands, either from the outside or inside of the country. This is because the lack of export, which makes companies tend to decrease their productions. In addition, the decrease of re-export activities also occurs and then decreasing the service trade related to such activities. Moreover, there is also a decrease of the tourism service. The decreases of export and tourism activities, as well as other related activities cause the investment expenditure reduces, which is then leads to the decrease of GDP.

Meanwhile, the in-conducive economic condition and reduced investment expenditure will encourage companies to decrease salary and office hours, and perform dismissal. This certainly decreases revenues, which then may weaken the customer's interest to expend and decreases the overall expenditure of domestic customers. Those decreases will finally lead to the decrease of GDP growth, see Table V.1.

Table V.1 Economic Growth in Terms of Demand						
Sector	Q1-08	Q2-08	Q3-08	Q4-08	Q1-09	Q2-09
Total Consumption	5.5	5.5	6.3	6.4	7.2	6.3
Household Consumption	5.7	5.5	5.3	4.8	5.8	4.8
Government Consumption	3.6	5.3	14.1	16.41	9.2	17.0
GFCF	13.7	12.0	12.2	9.1	3.5	2.7
Exports of goods & services	13.6	12.4	10.6	1.8	(19.1)	(15.7)
Imports of goods & services	18.0	16.1	11.0	(3.5)	(24.1)	(23.9)
Gross Domestic Product	6.2	6.4	6.4	5.2	4.4	4.0

Source: Central Bureau of Statistics, processed

The national economy has a significant decrease since Quarter IV-2008, which is estimated as the impact of export decrease since the economies of trade partners run slowly. Meanwhile, the domestic consumption growth also runs slow, estimated resulting from the cost and salary decreases. Moreover, investment also decreases along with the decrease of domestic and external demands. This delay causes the import commodities of capital goods, consumption and raw material tend to decrease.

Meanwhile, in terms of supply, there occurs a decrease on the economic growth since Quarter 4-2009, except on the electricity, gas, water and transportation sectors. This is related to the high uncertainty of global economy that makes businessmen delay their investment and business expansions. The growth of manufacturing industrial sector continuously runs slowly, estimated related to the unrecovered demands, particularly the export demand. This lack of demand causes the suboptimal use of available capacity that encourages companies to delay their investment activities. If it is seen from the structure, the highest decrease of distribution is in the manufacturing industrial sector coming from the transportation tools, machine and its tools, drink and tobacco and chemical subsectors and goods made from rubber. See Table V.2.

Sector	Q1-08	Q2-08	Q3-08	Q4-08	Q1-09	Q2-09
Agriculture	6.3	4.8	3.4	4.7	5.3	2.4
Mining	(1.7)	(0.5)	2.1	2.1	2.4	2.4
Manufacturing	4.3	4.2	4.3	1.8	1.5	1.5
Industry Electricity, Gas & Water	12.3	11.8	10.4	9.3	11.4	15.4
Building	8.0	8.1	7.6	5.7	6.3	6.4
Trading, Hotel & Restaurant	6.9	8.1	8.4	5.6	0.5	(0.1)
Transportation	18.3	17.3	15.5	15.8	17.1	17.5
Finance	8.3	8.7	8.6	7.4	6.3	5.3
Services	5.9	6.7	7.2	6.0	6.8	7.4
GDP	6.2	6.4	6.4	5.2	4.4	4.0

Source: Central Bureau of Statistics, processed

Trade, hotel and restaurant (THR) sectors grow slowly, assumed particularly resulting from the decrease of demands due to the low purchasing power of customers as the results of revenue decrease and dismissal increase, as well as the import performance decrease. Most of the commodity groups show the slow trend, particularly for durables and also the average level of hotel staying in Jakarta and Bali, which indicates the decrease. Meanwhile, the banking credits that have been distributed to the trade sector also decrease.

The decrease of agricultural sector is estimated to be lower due to the end of harvest time, also influenced by the delay of plantation subsector that is related to the decreases of export demands and plantation commodity prices. Meanwhile, the highest delay of agricultural sector comes from the food plants subsector and the performance of plantation subsector, excluding oil palm.

The decrease of GDP growth is not independent from the dynamics of regional economic growth since Indonesia consists of several provinces, which respectively has different characteristics. Therefore, the impact of global financial crisis to regional finance is assumed may influence the regional economic variables, suitable to the economic condition in such area. Moreover, there are several different economic and non-economic factors between areas, which certainly influence the intensity of such impact in each area.

There occurs quite sharp decrease of the national economy growth since Quarter III-2008, happened in almost all of areas, such as Sumatra, Jakarta, Jabalnustra and Kalisulampua. In Sumatra, the decrease of economic growth particularly happens in South and Central Sumatera, assumed caused by the export decrease and the household consumption. The export decrease rises mainly for primary commodities such as oil palm, rubber, oil and gas as well as other mining goods. In addition, there occurs a decrease of export commodity price as well that leads to the decrease of revenues and finally influences the decrease of consumption.

Table V.3 Economic Growth (yoy, %)											
Area/Zona	2007				2008				2009		Segment (Average of 2007-2009)
	Q-I	Q-II	Q-III	Q-IV	Q-I	Q-II	Q-III	Q-IV	Q-I	Q-II	
National	6.0	6.6	6.6	5.8	6.2	6.4	6.4	5.2	4.4	4.5	
Sumatera	4.3	5.5	5.4	4.7	4.9	4.9	4.8	3.9	3.1	3.2	21.6
NorthSumatera	3.4	6.3	5.5	2.1	3.0	1.8	1.8	3.1	2.0	2.9	7.1
Central Sumatera	4.8	4.5	5.1	5.5	5.2	7.1	6.8	5.4	4.0	3.1	9.0
South Sumatera	4.6	6.1	5.8	6.7	7.1	5.4	5.4	2.6	2.7	3.7	5.5
Jakarta	6.3	6.3	6.4	6.7	6.3	6.1	6.1	6.2	5.2	5.1	17.7
Jabalnustra	5.7	6.2	6.0	6.3	6.2	5.2	6.3	5.0	4.5	4.4	45.5
West Java	5.7	6.2	6.4	7.1	7.0	4.5	6.6	4.8	4.4	4.1	18.1
Central Java	4.4	6.1	5.7	5.7	6.0	5.2	6.4	4.0	4.1	4.7	9.4
East Java	5.5	6.2	6.3	6.4	6.0	6.3	6.2	5.4	4.5	4.5	15.3
Bali-Nusa Tenggara	13.0	6.1	2.2	2.5	3.3	3.7	4.8	6.6	6.4	5.1	2.7
Kalisulampua	5.9	6.2	3.4	3.4	3.5	4.8	7.3	5.9	5.4	5.8	15.0
Kalimantan	2.4	3.2	3.6	4.8	5.7	5.9	5.4	2.8	1.7	2.9	8.8
Sulawesi, Papua	11.3	10.7	3.0	1.4	0.3	3.2	10.1	10.4	11.0	9.9	6.2

Source: Central Bureau of Statistics, processed

The economic performance of all regions grows slowly. The delay occurs in most of provinces including provinces having significant contributions to the national economic growth, such as West Java, North Sumatera, Riau, and East Kalimantan. This causes the national economic growth runs slowly. Although in general, the impacts of such crisis still may be felt, several provinces still own high growth, such as Central Sulawesi and Riau Islands.

The global financial crisis existing since from Quarter II-2008 has delayed the export and consumption performances of regions, which makes the economic growth runs slowly. Regions depending on the export then get the impact of the decrease of world demand and commodity price. The delay of export growth particularly occurs in Sumatera, Kalimantan, Papua, and some areas of Java, which causes people's revenue experiences a decrease. This condition gets worse since the encourage of consumption financing in provinces decreases, especially for the consumption credit.

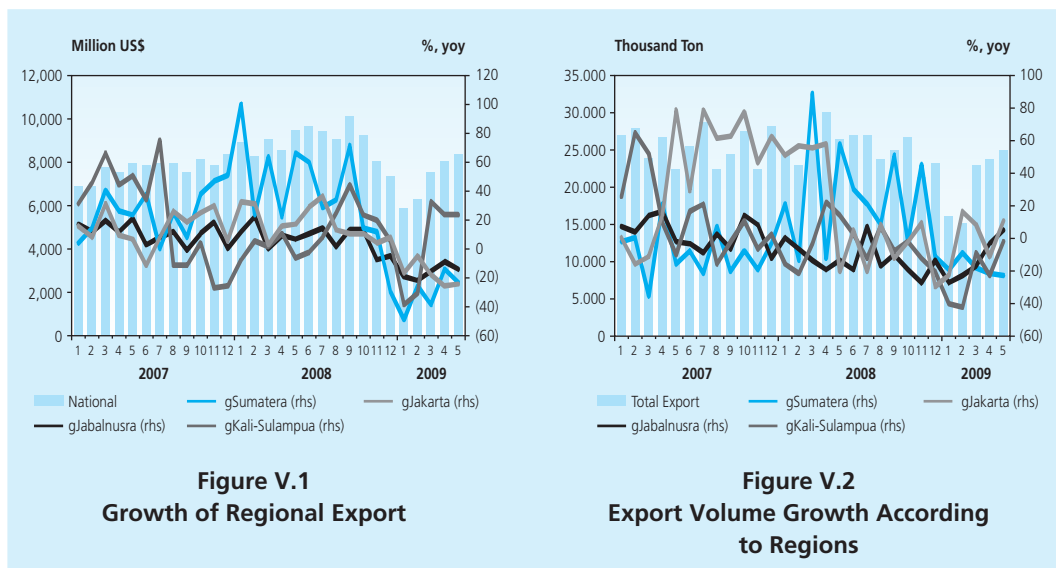

Household consumption also decreases, remarked by the decrease of motor vehicle sales and the growth of consumption goods import. This is in accordance with the dismissal, which makes pressures to the people purchasing power, is assumed still continue. However, revenues coming from the harvest time at the end of Quarter I-2009 and the realization of the 13th civil official salary, as well as the expenditure for the upcoming Presidential General Election are estimated may hold the delay of people consumption. In accordance to this, several consumption indicators show some recovery in Jakarta and Sumatera as seen from the retail purchase indicators

in Jakarta, Bandung, Semarang and Surabaya. In addition, the result of customer survey recognizes that customer belief has tended to be stronger since the early of 2009 as it is encouraged by the revenue increase expectation and the job opportunity recovery.

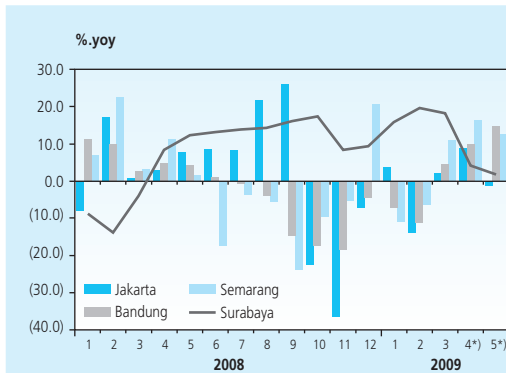

Figure V.3
Real Index Growth of Retail Purchase

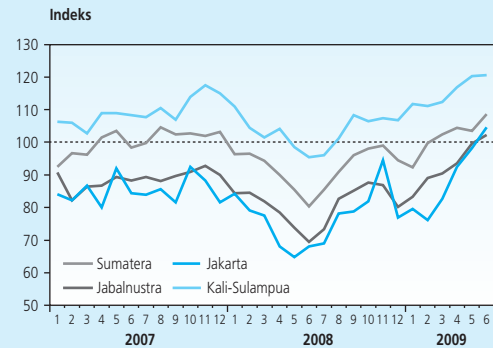

Figure V.4
Index of Consumer Confidence

Explicitly, the explanation above describes impacts occurred after the crisis. This paper conducts an inferential testing to recognize whether the effect of the global crisis is significant or not to the macro condition of Indonesia's economy as illustrated above. Moreover, this paper also examines the significance and the linkage level between one macro element and the others in one simultaneous macro model framework. The conducted study is focused on the analysis of crisis impact to the national economy and several areas viewed from the output and the forming components, namely consumption, investment, export and import, as well as inflation. The data used is quarterly data within period of time starts from Quarter I/1993 to Quarter IV/2008.

The following chapter of this paper explains the fundamental theories, whereas the third chapter discusses about the study methodology and the data used. The estimate and analysis results are discussed in the fourth chapter, while conclusion and suggestion become the closing.

II. THEORY

Demand on the economic outputs of a country within open economy coming from consumption (C), investment (I), government expenditure (G), export (X) and import (M). This chapter explains the fundamental theories that influence every aggregate component.

The consumption theory of Keynes states that consumption is particularly influenced by disposable income (Mankiw, 2003). Disposable income is revenue reduced by tax, $Y_d = Y - T$ where tax is the exogenous factor or the determined factor.

In the inter-temporal analysis, the consumption action is also influenced by interest (i). High interest will encourage consumption decrease since people tend to remove their consumptions to the next period. On the other hand, when interest decreases, people tend to spend than to save. The empirical model that may be used to consider both variables is as follows:

$$C_t = \alpha_t + \beta Y_{dt} + \lambda i_t + e_t$$

Where i_t is the real interest and α_t expresses the basic consumption, which is not influenced by the revenue level. Slope of disposable income is a variation of revenue, which is permanent within transitory (Friedman, 1957).

The second aggregate component is an investment that greatly depends on the capital cost or the real interest rate (Mankiw, 2003). However, several studies submit other variables into the investment equation. Stiroh (2000) states that output influences investment. Investment is consumption in the form of capital goods (plants and equipments), buildings, and inventories that increase the capital stock. In determining an investment, businessmen will consider for the credit interest rate, if the credit interest rate is high, they will decrease the credit. On the other hand, if the credit interest rate decreases, they will increase the credit (Ehrman dkk, 2001). According to Mojon², the credit interest rate or the market interest is influenced by the reference interest of central bank or monetary authority. The other factor that is influenced by investment is the economic condition factor, which is reflected from the output (GDP or GDRP). If the economic condition is good, companies will invest more. The formula is as follows:

$$I_t = \alpha_t + \beta i_t + \lambda cr_t + \lambda Y_t + e_t$$

Where I_t = Investment, i_d = real interest, cr = country risk and Y is the output such as the previous notation.

Country risk of certain country influences the people expectation to the prospect of related country's economy, which is reflected from the investment decisions to be taken by such country. High risk will decrease foreign investor's trust and will give negative pressure to investment.

2 Mojon, B, "Financial Structure and the Interest Rate Line of ECB Monetary Policy", ECB Working Paper No. 40, 2000.

Moreover, the government expenditure notified with G symbol is the determined exogenous factor. Government expenditure is a really significant tool in influencing output, inflation and unemployment in a short term since it has bigger multiplier effect than the household consumption. Government expenditure sincerely depends on the amount of tax revenues (export and income) and financing. In this study, government expenditure is placed as the exogenous variable within a consideration that such variable really depends on the government decision and not determined in the system.

If the economy of a country or a region is open, trade between countries and regions will occur. Therefore, the export and import factors will also influence the economic output of such country or region. Export means the delivery or purchase of goods from a country or region to the outside of such country or region. Export value will be determined by the economic level of such destination country or region. The foreign output factor will provide positive influence, where the increase of foreign output will increase the export demand of such country.

The exchange rate also plays role in influencing the export demand. The exchange rate depreciation in the country will cause the product price of the country is cheap, which makes the product competitive power of such country increases. In that case, the decrease of exchange rate will be followed by the increase of export and impact the output increase as well (Hallwood and MacDonald, 2000).

In addition, the output factor of other countries also influences the export. When the output of a country (country A) decreases, the purchasing power of country A will decrease and cause the decrease of such country's import. Meanwhile, country B, which is the main exporter to country A will get an impact in the form of its export decrease. Therefore, the decrease of other country's output will cause the export of our country decreases, primarily if such country is our country's main export destination countries such as USA, Japan, and China.

Related to the role of oil in the sufficiently busy international trade activities, the variable of oil price also influences the total of export, particularly in our country, which is one of the oil exporters. So, the following export equation may be written as follows:

$$X_t = \alpha_t + \beta e_t + \lambda Y_t^* + \delta oil_t + \mu D_t + e_t$$

Where X = export, e = exchange rate (Rp/USD), Y* = US output, oil = world oil price and D is the crisis dummy variable.

On the other hand, import is more influenced by the economy inside the country, where revenue reflects the people purchasing power. Import value is also influenced by the movement

of exchange rate. Appreciation of exchange rate will be followed by the increase of import demand, particularly for the consumption goods. This is due to the appreciation of exchange rate, which means that the price of import goods will be cheaper so that the demand of such goods will increase. The import equation may be described as follows:

Different from export, import has marginal propensity to import so that it is really influenced by domestic economy. The total of import compared to the export is a form of domestic consumption that flows to abroad, which leads to the decrease of economic output. Besides the domestic output, import is also influenced by the movement of exchange rate. The appreciation of exchange rate will be followed by the increase of import demand, particularly for the consumption goods. This is due to the appreciation of exchange rate, which means that the price of import goods will be cheaper so that the goods demand will increase as well, as explained by the following equation:

$$M_t = \alpha_t + \beta e_t + \lambda Y_t + \delta P_t^* + \mu D_t + e_t$$

Where M = import, e = exchange rate (Rp/USD), Y = national output, P^* = CPI US and D is the dummy variable, which is crisis. Aggregately, in the open condition, the economic output from the demand side follows the identity below:

$$Y = C + I + G + X - M$$

The inflation model, based on the theory of Philips Curve (Mankiw, 2003), submits the inflation expectation, output gap and supply shock variables. For the inflation expectation variable, proxy variable will be used, namely : 1-month lag inflation within an assumption that people will perform the current inflation expectation based on the previous 1-month inflation (adaptive inflation theory). Output gap is a difference between the actual GDRP and the potential GDRP, where potential GDRP variable is in the form of GDRP trend. Meanwhile, the shock supply variable will be represented by the fuel price or the exchange rate of Rupiah to US dollar. The formula is as follows:

$$\pi_t = \pi_t^e + \beta (Y_t - \bar{Y}_t) + v_t$$

Where π = inflation, π^e = inflation expectation, Y = actual output, \bar{Y} = potential output and v = supply shock

The world's financial crisis impacts the national economy, including its regional economies. Such financial crisis is marked by the turbulence raised in the stock and foreign exchange markets. In foreign exchange market, depreciation of Rupiah exchange rate against US dollar directly impacts the export and import. Meanwhile, the decrease of world economic growth, which is marked by the decrease of GDP in almost all of the countries in the world, encourages the decrease of export demand. For Indonesia, such economic decrease makes the consumption and investment reduce.

III. METHODOLOGY

III.1 Estimation Technique

This study uses the econometric approach, namely the simultaneous equation or more famous as the simultaneous model. Simultaneous model will be used to capture every variable change, which is influenced by the world financial crisis in the form of simulation. This simulation result is expected may explain the impact of such crisis to the Indonesia's economy.

The simultaneous equation is the equation compilation where the dependent variable of one or some equations is also the independent variable of some other equations. Briefly, the variable of simultaneous model may have double roles, either as independent or dependent variable (Gujarati, 2003).

Identification of model structure is the initial stage in arranging such simultaneous model, which determines whether or not the parameter estimate can be solved. In general, there are three conditions resulted from such identification result, namely:

1. Exactly identified, a condition where the parameter value obtained is unique, which is only one value for each structural parameter coefficient.
2. Over identified, a condition where the structural equation parameter obtained is more than one.
3. Under identified, where the structural equation parameter is not obtained since the condition does not fulfill the minimum calculation requirements for one of its parameters.

The identification process may use two methods, namely: Order Condition and Rank Condition (Enders, 2004), in which the order condition procedure is not enough and needs to be added with the rank condition procedure as a requirement for sufficiency. In order to make the simultaneous equation system within M structural equation can be identified, at least it has to own an endogenous variable $(M-1)$.

For some m endogenous variables in the model, if K total is the explanatory variable (predetermined), whereas k is the number of explanatory variables in a certain equation, then the order condition shall follow the requirement below:

- a. If $(K-k) = (m-1)$, the equation is declared *exactly identified*.
- b. If $(K-k) > (m-1)$, the equation is declared *over identified*.
- c. If $(K-k) < (m-1)$, the equation is declared *under identified*.

If an equation is *over identified or exactly identified*, the equation may be solved.

There are 3 estimation techniques that may be used, namely: (i) Indirect *Least Squares* (ILS), used in the exactly identified structural equation; (ii) *Ordinary Least Square* (OLS), used in the over identified structural equation, but with one condition: there is no any endogeneity problem, or on the other words, there is no linkage between equations, and the simultaneous equation estimate will therefore give the same result when every equation is estimated separately, and if there is endogeneity problem, the method should be used is the *Two Stages Least Squares* (TSLS); and (iii) *Two Stages Least Squares* (TSLS), used to obtain the structural parameter value in an *over identified* equation and owns *endogeneity problem*.

To choose an estimation technique, it is considered to conduct it based on 2 matters, namely: (i) comparison identification of the total endogenous and exogenous variables explained above, and (ii) the endogeneity problem existing in the structural equation³. Technically, this endogeneity problem may be reflected in the mismatch covarian matrix structure between equations whose testing may be conducted by using the Hausman specific test.

III.2 Empirical Model for Simultaneous Equation

The next equations used to form the simultaneous model are as follows:

1. $C_t = \alpha_t + \beta Y_{dt} + \lambda i_{t-3} + e_t$
2. $I_t = \alpha_t + \beta i_{t-4} + \lambda cr_{t-4} + \gamma Y_{t-4} + e_t$
3. $X_t = \alpha_t + \beta er_t + \lambda Y_t^* + \delta oil_t + \mu D_t + e_t$
4. $M_t = \alpha_t + \beta er_t + \lambda Y_{t-1} + \delta P_t^* + \mu D_t + e_t$
5. $Y_t = C_t + I_t + G_t + X_t - M_t$
6. $\pi_t = \pi_t^e + \beta (Y_t - \bar{Y}_t) + er_t + e$

The simultaneous linkage between variables and the lines of such six equations are illustrated in the following chart:

³ See Hamilton (1994) for the detail explanation.

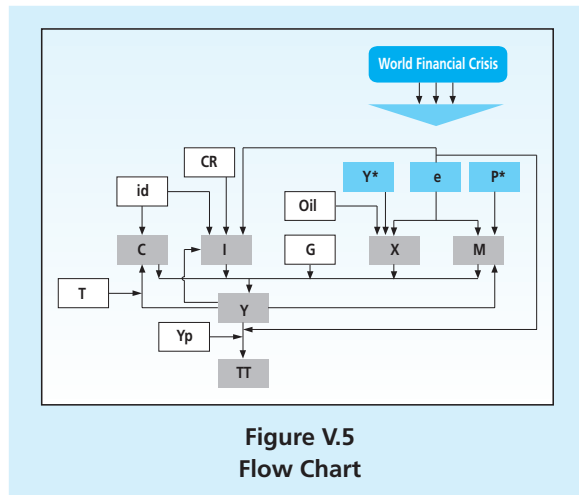

Figure V.5
Flow Chart

By using the procedures of order condition and rank condition, those six structural equations are over-identified. Consequently, the available equations may be finished by the methods of OLS and TSLS. As abovementioned, one of the weaknesses of the OLS method use in the simultaneous equation is the endogeneity problem, which if the equation contains it, then the use of OLS will produce an inefficient presumed parameter.

Based on the result of Hausman specific test, it is obtained that the equations of consumption, investment, and import contain an endogeneity problem. Therefore, those three equations must use TSLS to get a consistent and not bias result. Meanwhile, the export and inflation equation uses the OLS method in its estimate. Every equation is estimated partially within an error assumption in one equation that is not correlated with an error existing in the other equation⁴.

The simultaneous macro model above is applied in the national data. The data used in this study is in the form of quarterly data including the data of Quarter 1-1996 to Quarter 4-2008. For the data period of 1996 to 2001, interpolation is conducted from annual data to be quarterly data due to the data limitation. The similar model structure is also applied independently in every region, including in North Sumatera, West Sumatera, South Sumatera, West Java, Central Java, East Java, South Kalimantan and North Sulawesi⁵.

The model application of every region is adjusted to the characteristics of related region. One of the adjustment forms is the indicators selection to represent certain variables, such as

1 We understand that the assumption is too strong. The release of this assumption is of interest for the future study.

2 Performed by every KBI, namely: Medan KBI, Padang KBI, Palembang KBI, KBI Bandung KBI, Semarang KBI, Surabaya KBI, Banjarmasin KBI, and Manado KBI.

foreign demand (approached with foreign GDP), which is different for some regions in accordance with their own characteristics. The data source comes from the Central Bureau of Statistics and the CEIC Data. The data used covers the periods of 1993-2008.

IV. RESULTS AND ANALYSIS

IV.1 Estimation of Consumption Equation

In accordance with the basic theory of Keynes, the estimate result for the consumption model using the TSLS approach shows the positive impact of disposable income to consumption. Further, the interest rate has negative impacts consumption, along with the increase of opportunity cost in expensing money. The estimate result is as follows:

$$C_t = 7.12 + 0.63 Y_{dt} - 0.003 i_{t-3} + e_t$$

$$(0.36)^{***} \quad (0.04)^{***} \quad (0.002)^*$$

$$R^2 = 0.92, DW = 1.23, \text{ Instrument list : } Y_{dt-1} T_{t-1}$$

All variables are estimated in the form of manual logarithm. The estimate result shows autonomous consumption that owns a positive and significant value in accordance with the theory. Marginal Propensity to Consume (MPC) of 0.63 for the national scale shows a consumption change of 0.63% for every 1% change of disposable income. Compared to the period before the crisis, 1986-1996, Indonesia MPC slightly decreases from the number of 0.63. Relatively, MPC in Indonesia is almost the same with Korea and Japan, 0.634 and 0.620 respectively. This propensity to consume is higher than China (0.540) and Singapore (0.478), but is lower than Philippine (0.835) and Hong Kong (0.846)⁶. An investigation result on some observed provinces shows that some MPCs are slightly different from the national MPC. The highest MPC is owned by North Sumatera Province, which is 0.94 (Table V.4). On the other hand, South Sumatera Province has the lowest MPC, which is 0.40. This is related to the different characteristics of every region.

For the variable of interest rate, the estimate result shows a quite small consumption response to the change of interest rate. Consumption elasticity to the interest rate is -0.003, which means that the increase of interest rate is 10%, only responded by the consumption decrease of 0.03%. Theoretically, the increase of deposit interest will increase the cost of

⁶ The Estimation of these countries uses the data existing in the periods of 1985-1996. This document is downloaded from <http://www.gsid.nagoya-u.ac.jp/project/apec/outcomes/paper99/27/Appendix1.pdf>

Table V.4 Marginal Propensity to Consume of Some Region		
No	Province	Disposable Income
1	North Sumatera	0.94
2	West Sumatera	0.88
3	South Sumatera	0.40
4	West Java	0.82
5	Central Java	0.66
6	East Java	0.86
7	South Kalimantan	0.89
8	North Sulawesi	0.77

Source: Study Result of Each KBI

money use of the current period, which then will encourage customers to decrease consumption and switch it to the next period. The estimate result that reflects the small response of consumption is very potential, resulting from the low living standard of the people and their struggle in fulfilling the basic needs.

IV.2 Estimate for Investment Equation

Investment equation uses the real interest and output variables as the main variables and submits the country risk variable, which covers political, economical, and financial risks. The result of regression equation using the TSLS method is as follows:

$$I_t = 2.29 - 0.02 i_{t-4} + 0.58 Y_{t-4} + 0.03 cr_t + e_t$$

$$(1.72) \quad (0.008)** \quad (0.14)*** \quad (0.005)***$$

$$R^2 = 0.52, DW = 0.77, \text{Instrument list: } C d_t C d_{t-1} C_{t-1}$$

From such regression result, it is found that the real interest gives negative and significant impacts investment, this is in accordance with a theory stating that the relationship of real interest and real investment is contradictive (Mankiw, 2003). The increase of real interest will cause investment decrease, but the effect is relatively small, where its coefficient is minus 0.019, which means that the real interest increase of 1% will cause an investment decrease of 1.9%. Contrary, if the real interest decreases 1%, it will be followed with an investment increase of 1.9%.

Commonly, in Indonesia and other developing countries, the total cost of capital and accessibility on such capital becomes the main barrier. Along with the lack of external demands and the uncertainty factor of global economy, investment growth has run slowly since Quarter IV-2008. This is indicated by the investment guiding indicator existing in the contraction cycle and by the decrease of the capital goods import growth indicator. This slowing down of investment particularly occurs in Sumatera and Jabalnustra, mainly caused by the decrease of non-building investment that is related to the lack of external absorption power and the unrecovered risk of global uncertainty.

To the country risk variable, the result of inferential testing result shows a contradictive mark to the theory. The elasticity obtained is 0.03, which means that the risk increase of 1 % is only caused by the investment increase of 0.03%. This anomaly should be reviewed further.

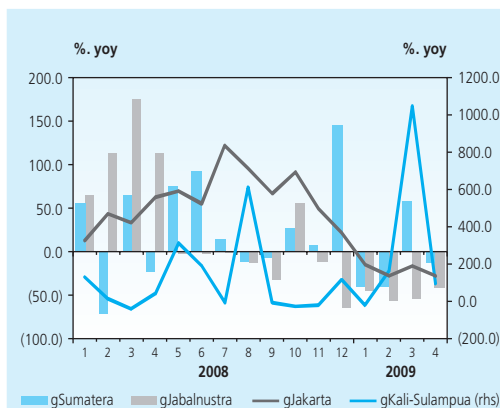

Figure V.6
Growth of Capital Goods Import Volume
in Indonesia

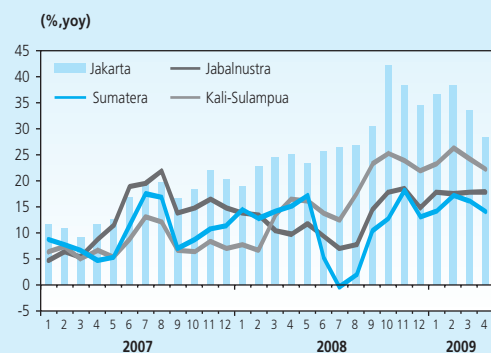

Figure V.7
Growth of Investment Real Credit
in Indonesia

To the domestic output variable, this estimate result shows output positive effect to investment. The high output of a country or a region will encourage the increase of investment, either domestic or foreign investment. This is because the high output shows the economic prospect of such country or region, which then encourages the investor interest to invest in such area.

Nationally, the regression result shows that output within a lag of previous year has a positive and significant effect within an elasticity level of 0.58. Compared to the explanatory variable, the output effect is the biggest one. It shows that the national economic condition or prospect is the most important factors in determining investment.

The implementations of similar model structure on such eight provinces above in Indonesia show significant results on the main explanatory variables, namely the GDRP and the real interest rate, within direction that is in accordance with the theory. From such implementations, it is recognized that the effects of output to investment in North Sumatera and West Java are relatively the highest within respectively elasticity levels of 1.29 and 1.27. Meanwhile, the output elasticity level of South Sumatera is the lowest one, which is 0.11 (Table V.5). On the other hand, the coefficient of real interest in several provinces is quite the same, namely 0.01 to minus 0.03, close to the real interest coefficient of national level, which is minus 0.02, except Central Java that has the coefficient of 0.78.

No	Province	GDRP	Real Interest Rate
1	North Sumatera	1.29	-0.01
2	West Sumatera	0.35	-0.01
3	South Sumatera	0.11	-0.002
4	West Java	1.27	-0.01
5	Central Java	0.71	-0.78
6	East Java	0.79	-0.001
7	South Kalimantan	0.92	-0.03
8	North Sulawesi	0.61	-0.01

Source: Study Result of Each KBI

The non-building investment growth tends to runs slowly in accordance with the decrease of foreign machine and equipment demands and the decrease of capital goods import. The delay of fiscal stimulus distribution and infrastructure project realization encourages the lack tendency of businessmen although the domestic condition before the Presidential General Election is relatively stable. This indication is encouraged by the cement consumption growth, which gradually decreases in Java and Sumatera. In addition, investment financing support in the form of real investment credit indicates to decrease as well. For that reason, the investment activity interest of businessmen slightly decreases, which is reflected from the decrease of Business Tendency Index due to the decrease of input goods order and foreign order that is accompanied with the decrease of real purchase price.

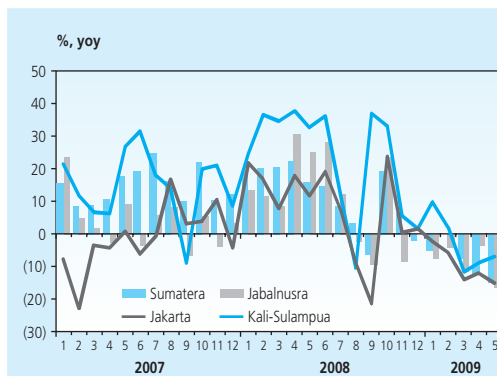

Figure V.8
Development of Cement Consumption
in Indonesia

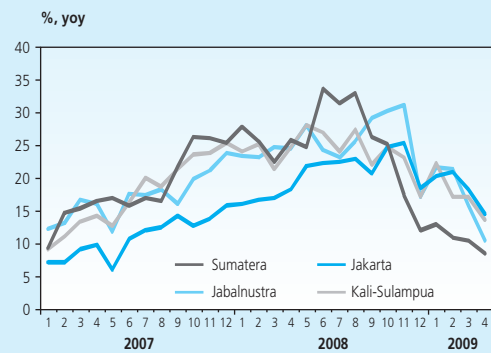

Figure V.9
Growth of Working Model Credit
According to Regions in Indonesia

IV.3 Estimate for Export Equation

Export Equation uses independent variable of USA GDP as the representative of the world economic growth. This is important since the main objective of this study is to find out the impact of the world financial crisis, which is followed by the decrease of the world economic growth. In addition, the export equation also submits the variables of the world oil price and the exchange rate change of Rupiah to US Dollar. The result of empirical testing that uses the method of OLS is as follows:

$$X_t = 4.05 + 0.84 Y_t^* + 0.006 oil_t + 0.31 \Delta e_t + 0.19 D_t + e_t$$

$$(2.09)^{**} \quad (0.23)^{***} \quad (0.001)^{***} \quad (0.10)^{***} \quad (0.06)^{***}$$

$$R^2 = 0.84; \quad DW = 1.3$$

The regression result shows that the world economy, which is represented by USA GDP has positive and significant impacts the national export within elasticity of 0.84. This is in accordance with the theory and the total of elasticity, not too surprising since USA and Japan are the main trade partners of Indonesia and other countries.

Meanwhile, the world oil price has positive and significant impact to the export. This is in accordance with the high total of oil and gas export so that the increase of oil price is be followed by the increase of export. The effect of the exchange rate change of Rupiah to US Dollar is positive and significant as well. In accordance with the theory, the depreciation of exchange rate will be followed by the increase of export value. Dummy variable used is the dummy of the 1998 crisis period, where the result has significant effect to the export.

Table V.6 Export Elasticity to the GDPs of Other Countries		
No	Province	GDP (Country)
1	North Sumatera	1.26 (Japan)
2	West Sumatera	0.05 (China)
3	South Sumatera	1.35 (USA)
4	West Java	8.54 (USA)
5	Central Java	0.73 (USA)
6	East Java	0.67* (China)
7	South Kalimantan	1.14 (Japan)
8	North Sulawesi	0.69(China)

Source: Study Result of Each KBI

The impact of the global financial crisis is not only to the national economy, but also to the regional economy. This may be seen from the export equation regression, which is represented by eight provinces. Table 6 shows the impact of the world GDP, which is represented by three countries, namely USA, China and Japan that gives positive and significant impact within quite high level of elasticity.

The impact of USA economy, for instance, to West Java Province, is so great, which is shown in the elasticity level of USA GDP to the West Java Province's export of 8.54. United States is one of the main export destination countries of West Java, where 1% decrease of USA GDP will encourage the export decrease of West Java of 8.54%. The impact of global financial crisis to West Java is marked by the export decrease, particularly for machine and electronic equipments.

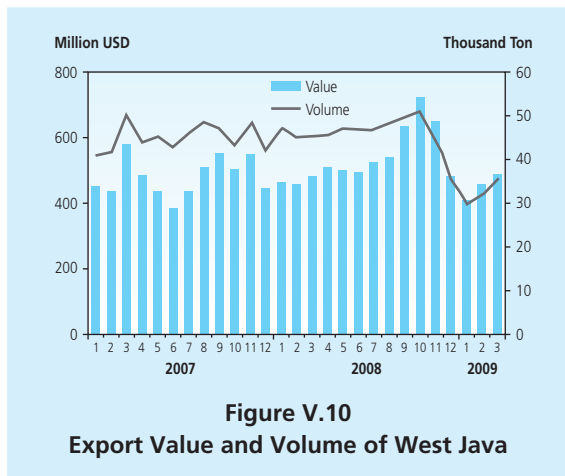

Figure V.10
Export Value and Volume of West Java

The high influence of trade partner country's GDP such as USA's is also seen in other regions in Indonesia. This is clearly recognized that the export development in several superior non-oil and gas commodities, particularly animal/plant fat and oil, rubber and goods made from rubber continuously decreases.

Based on the available data, this export performance decrease does not occur continuously. Entering the year of 2009, the price of international commodities and the performance of trade partner countries, such as India and China are better, while demands from the emerging market countries is getting to increase as well, particularly for the CPO and coal commodities (See Figure 11 to 14). The export recovery indication in regions also shows some improvements, at least the decrease of main commodities in every region, such as CPO, rubber (Sumatera), coal, copper (Kali-Sulampua), and TPT, and foot wear (Jabalnustra) runs slowly.

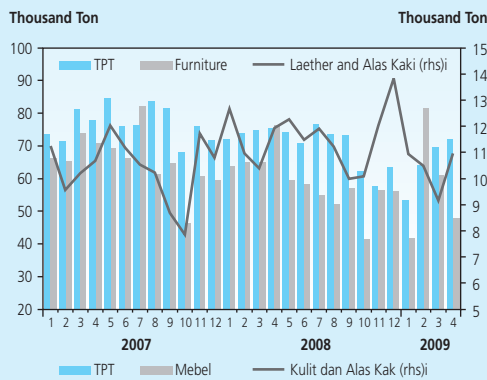

Figure V.11
Development of Superior Export Value in Jabalnustra

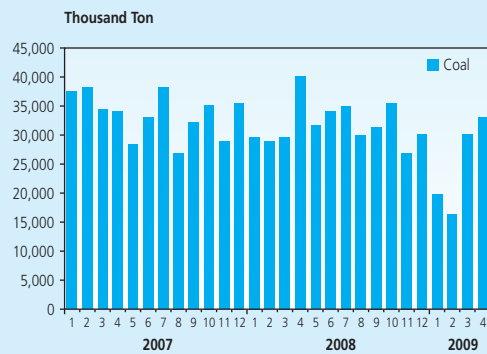

Figure V.12
Development of Superior Export Value in Kali-Sulampua

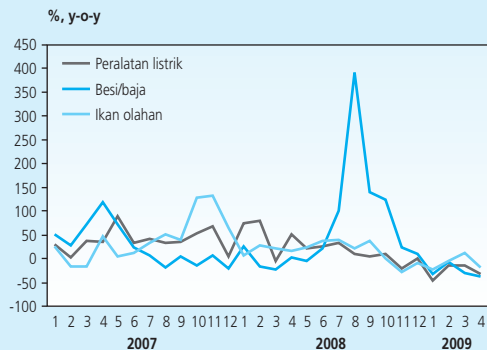

Figure V.13
Development of Superior Export Value in Jakarta

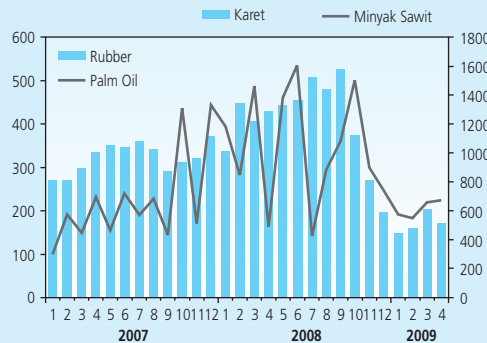

Figure V.14
Development of Superior Export Value in Sumatera

IV.4. Estimate for Import Equation

For import equation, this study uses domestic output factor, the world price index represented by USA CPI, real exchange rate and crisis dummy. The result of empirical testing is as follows:

$$M_t = -14.3 - 0.32e_t - 0.007p_t^* + 2.23Y_{t-1} + 0.4D_t + e_t$$

$$(4.91)^{***} \quad (0.15)^{**} \quad (0.003)^{***} \quad (0.40)^{**} \quad (0.18)^{***}$$

$$R^2 = 0.82, \text{ DW} = 1.1, \text{ Instrument list: } C d_t C d_{t-1} T_t C_{t-1}$$

The result of import equation regression by using TSLS method shows that the impact of output within one Quarter lag is positive and significant within the elasticity level of 2.23. This is in accordance with a theory, which states that the higher output of a country or a region, the higher increase of its import demand.

Meanwhile, the impact of exchange rate to the import is negative and significant within a coefficient of minus 0.32. Exchange rate depreciation of Rupiah to US Dollar will be followed by the decrease of import. This is because the import demand is decreased along with the increase of import commodities price as the consequence of the fall of Rupiah exchange rate to foreign currency (US Dollar). A contradictive condition happens if the exchange rate is appreciated, which impacts the decrease of import commodities price in the form of Rupiah, so that the import commodities demand increases.

The prices of foreign goods also impact the import, where the increase of foreign goods measured with foreign *customer price index* (CPI) impacts the import decrease. Therefore, relationship between import and foreign goods prices is negatively correlated. The result of regression states that USA CPI representing the foreign goods price provides negative and significant impact within a coefficient of minus 0.007. The crisis dummy variable is also significant from the result of testing.

It is noted from the empirical testing result in regional import equation, represented by eight provinces, that the outputs of those regions give positive and significant impacts. GDRP elasticity level of West Java Province's import is seen as the highest one compared to the other seven provinces, which is 2.93 (Table V.7). This indicates that the consumption behavior, mainly the dominant import proposition of West Java, is in the form of consumption goods import. In general, the movement of import goods in every region is shown in Figure 15 to Figure 18.

Table V.7 GDRP Effect to Import		
No	Province	GDP (Country)
1	North Sumatera	1.34
2	West Sumatera	2.37
3	South Sumatera	0.60
4	West Java	2.93
5	Central Java	1.50
6	East Java	1.6
7	South Kalimantan	0.94
8	North Sulawesi	1.96

Source: Study Result of Each KBI

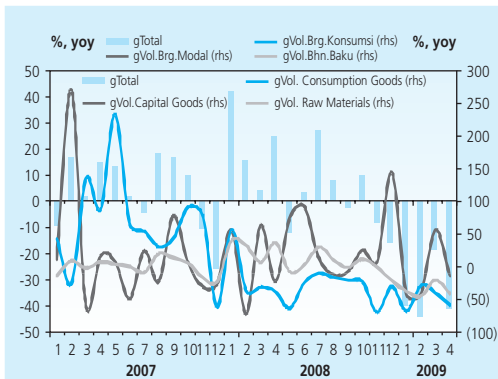

Figure V.15
Development of Sumatera's Import Volume

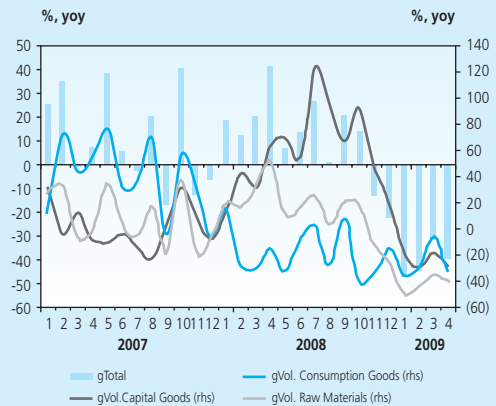

Figure V.16
Development of Jakarta's Import Volume

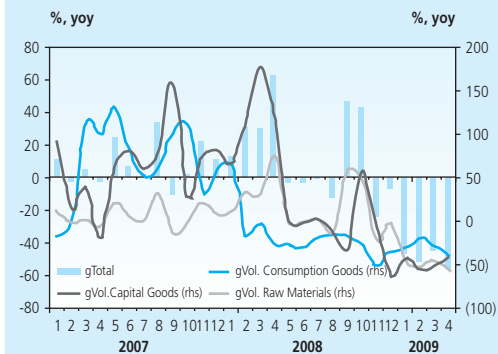

Figure V.17
Development of Jabalnustra's Import Volume

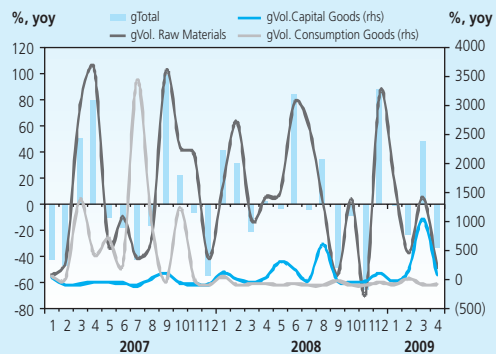

Figure V.18
Development of Kali-Sulampua's Import Volume

IV.5 Estimate for Inflation Equation

This inflation equation basically represents the demand side of an economy. The standard specification used is Philips Curve within three main components, namely inflation expectation, output gap, and supply shock that are represented by Rupiah exchange rate to US dollar. The estimate result on this supply is as follows:

$$\pi_t = 0.64 \pi_t^e + 0.64 (y_t - \bar{y}_t) + 0.27e_t + 19.7 D_t + e_t$$

(0.08)*** (0.31)** (0.09)*** (5.85)***

R² = 0.89, DW = 1.09

The inflation expectation has significant effect to the inflation level within fairly high coefficient of 0.64. In this model, the agent behavior is specified to follow the formulation process of adaptive expectation, namely by reflecting to the previous inflation level. From the empirical testing result of inflation equation on eight provinces, it is obtained a result relatively the same with the national regression result, where inflation expectation factor plays important roles. Even in some regions, the inflation expectation coefficient is higher than the national inflation expectation coefficient. It is noted that four provinces have inflation expectation coefficients higher than the national inflation expectation coefficient, namely North Sumatera, East Java, West Java, and South Kalimantan of 0.76, 0.74, 0.72, and 0.66 respectively (Table V.8).

Table V.8 Inflation Expectation Coefficient Impact to Regional Inflation		
No	Province	GDP (Country)
1	North Sumatera	0.76
2	West Sumatera	0.40
3	South Sumatera	0.64
4	West Java	0.72
5	Central Java	0.27
6	East Java	0.74
7	South Kalimantan	0.66
8	North Sulawesi	0.49

Source: Study Result of Each KBI

The gap output, which is the difference between the actual and natural outputs, gives positive impact to the inflation within elasticity of 0.64. The positive gap output condition in general shows the faster movement of the economy and in this condition, the inflation pressure increases.

Domestic economic activities are not the only gap output or the only cause of inflation. From the external side, the exchange rate movement of Rupiah to foreign currency also gives an impact to the output gap. This exchange rate variable is internalized into the empirical model to represent the external shock that affects the supply side.

A currency suffering from inflation has tendency to be depreciated and vice versa, a country whose currency is depreciated will face increased competition, which then encourages the aggregate demand and gives pressure to the inflation increase. The estimate result shows that this real exchange rate variable has significant effect to the price increase in general. In accordance with this basic theory, every 1% depreciation of Rupiah to US Dollar, the inflation will increase 0.27%.

Since Quarter IV-2008, the economic activities grow slowly in accordance with the decrease of demand. This lower sector growth may be confirmed by several indicators, namely the decreased utilizations of production capacity and Business Tendency Index of BPS including all of its formulation factors indicate delay. Meanwhile, the formulating variable of decreased BPS business tendency index is the use of production capacity, business revenue, and the total of office hours. In addition, there is an indication of increased total of dismissal.

Table V.9
Sector Growth of Quarter 1-2008 to Quarter 2-2009

Sector	Sumatera						Jakarta					
	Q.1-08	Q.2-08	Q.3-08	Q.4-08	Q.1-09	Q.2-09	Q.1-08	Q.2-08	Q.3-08	Q.4-08	Q.1-09	Q.2-09
Agriculture	6.8	5.1	4.1	1.5	1.7	2.8	1.4	(0.3)	1.4	1.4	1.4	(0.4)
Mining	(3.2)	0.4	(2.2)	(0.1)	(0.3)	(2.2)	1.5	0.1	0.0	0.0	0.4	0.3
Manufacturing	3.7	3.7	5.0	3.1	0.8	2.0	4.1	3.8	3.6	3.6	1.6	(0.2)
Electricity, Gas & Water	5.8	5.1	3.9	5.3	6.0	5.8	6.8	7.0	5.9	5.9	6.2	6.4
Building	9.7	8.3	7.9	7.9	5.6	5.3	7.5	7.6	7.8	7.8	6.3	6.5
Trade,Hotel & Restaurant	6.6	6.1	7.5	6.0	5.2	5.6	6.9	6.3	5.7	5.8	3.9	4.3
Transportation	9.1	7.9	9.1	8.9	8.3	7.6	15.0	14.8	15.0	14.8	15.6	15.1
Finance	13.3	10.9	12.2	7.2	5.0	5.9	4.1	4.2	4.8	4.8	4.3	4.4
Services	7.5	7.2	7.4	(1.1)	7.9	7.1	6.3	6.1	5.9	5.9	5.5	5.8
GRDP	4.9	4.9	4.8	3.9	3.1	3.2	6.3	6.1	6.2	6.2	5.2	5.1
Sector	Jabalnustra						Kali-Sulampua					
	Q.1-08	Q.2-08	Q.3-08	Q.4-08	Q.1-09	Q.2-09	Q.1-08	Q.2-08	Q.3-08	Q.4-08	Q.1-09	Q.2-09
Agriculture	11.1	(1.4)	0.9	0.8	4.0	4.8	5.8	5.6	4.2	0.1	1.6	3.6
Mining	3.7	(2.1)	3.9	5.6	2.3	7.0	8.3	7.5	6.2	11.8	8.3	9.2
Manufacturing	5.1	7.0	5.2	5.4	2.3	1.2	3.9	3.8	0.2	0.1	(0.1)	4.3
Electricity, Gas & Water	5.2	5.2	2.8	4.9	2.7	7.3	7.8	6.8	8.3	5.8	8.5	6.6
Building	3.8	4.0	9.5	9.8	5.6	6.5	11.0	12.5	10.3	9.3	9.9	7.2
Trade,Hotel & Restaurant	6.3	7.7	5.1	5.4	5.7	6.2	9.2	10.3	10.1	7.4	8.5	6.1
Transportation	4.1	5.3	6.0	5.6	9.9	8.6	10.4	10.6	10.7	9.5	8.1	4.4
Finance	5.9	7.8	7.8	7.3	6.9	6.3	8.4	9.4	8.3	7.6	7.4	3.6
Services	5.3	4.9	5.8	5.1	6.2	5.7	6.3	6.0	6.6	8.9	8.9	6.4
GRDP	6.4	5.2	4.9	5.0	4.5	4.4	7.1	7.2	5.8	5.9	5.4	5.8

The delay of supply varies across sectors and regions. In the agricultural sector, for example, the delay of agricultural credit in Sumatera has been seen since May 2008, while the increase in fact occurs in Kali Sulampua. For manufacturing industry, although Sumatera and Kali-Sulampua receive an increase, in overall, this sector grows quite slowly due to the decreased growth of manufacturing industrial sector in Jabalnustra and Kali-Sulampua, see Figure 19.

This delay is indicated by the decrease of material raw import volume, production capacity, and credit real growth in the industrial sector. The main influencing factor is the lack of external demand as the result of global economic crisis, which then decreases the industrial sector performance, particularly the export-oriented industrial subsector, such as non-iron basic metal, bamboo, wood, rattan, and oil and fat industries (See Figure 20 and Figure 21).

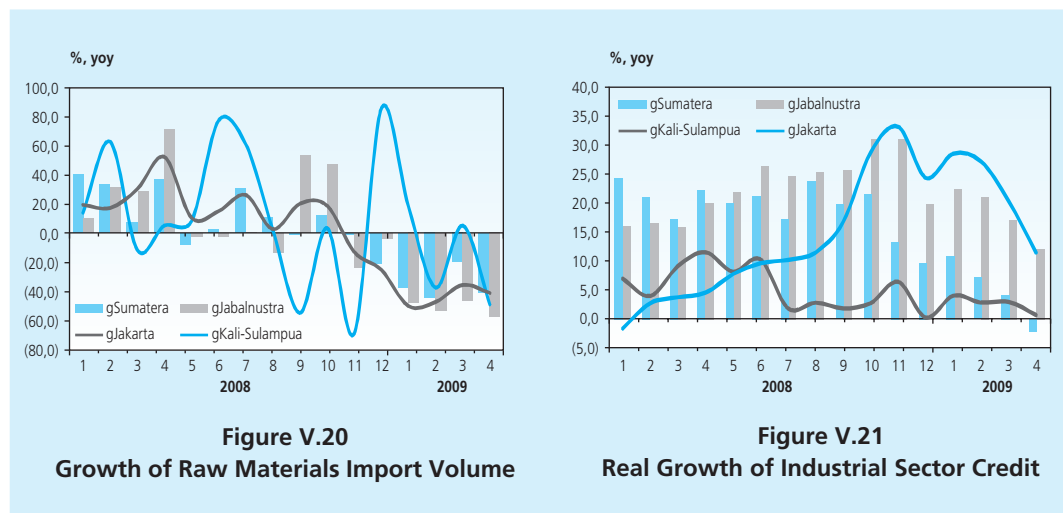
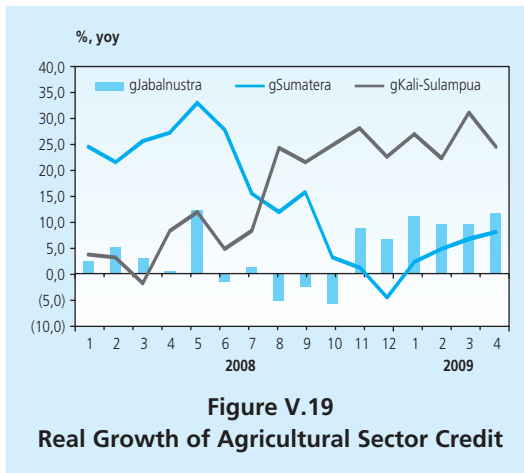

The mining sector is recovered due to the increase of non-oil and gas mining production. Such recovered prices of mining commodities and the presence of long term contract become an incentive for the increase of nickel, copper and coal productions in Kali-Sulampua. However, this sector experiences a contraction in Sumatera due to the decrease of oil and gas productions in NAD and Riau.

The existing delay mainly occurs due to the lack of export demand and the decrease of commodity price, such as those shown by the development of coal, ore, slag, metal ash, and aluminum exports. In addition, the delay of mining and digging sectors is also related to the decrease level of oil and gas mining productions, mainly in Riau and NAD since the wells of bore are already old.

Table V.10 Price and Production Developments of Copper and Gold in Indonesia		
Indonesia Mining Operations	First Quarter	
	2009	2008
Copper (millions of recoverable pounds)		
Production	404	200
Sales	369	207
Average realized price per pound	\$1.80	\$3.82
Gold (thousands of recoverable ounces)		
Production	570	246
Sales	521	251
Average realized price per ounce	\$904	\$932

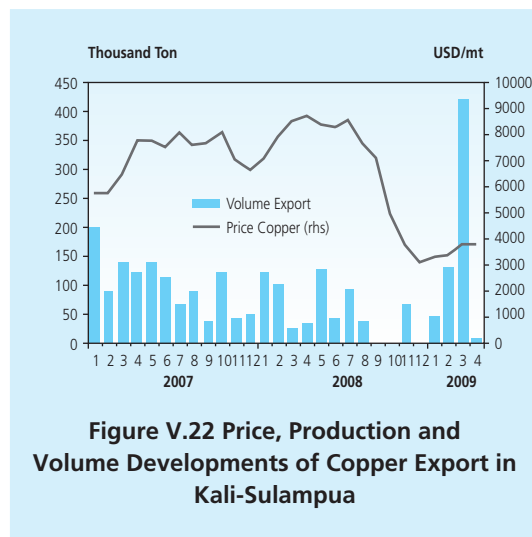

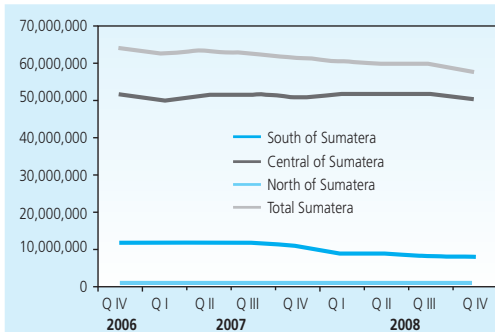
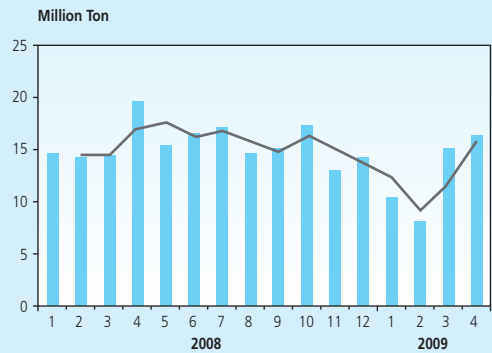

Figure V.23
Oil Production Development of Sumatera (Barrel)



Source : DSM-BI

Figure V.24
Coal Export Volume Development of Kalimantan

The output dynamics mentioned above interact with the exchange rate movement and inflation expectation in influencing the existing level of actual inflation. Those three variables simultaneously have an interaction with other variables available in the consumption, investment, export and import equations. The equation that closes and attaches every partial equation is the aggregate demand identity equation, namely: $Y = C + I + G + X - M$.

The validity of this simultaneous macro model is conducted by comparing the actual data with the simultaneous model result data (baseline). Figure 26 shows that the actual data and the result of baseline are sufficiently fitted, and therefore it may be concluded that the simultaneous model is valid enough to be used in performing simulation or projection⁷.

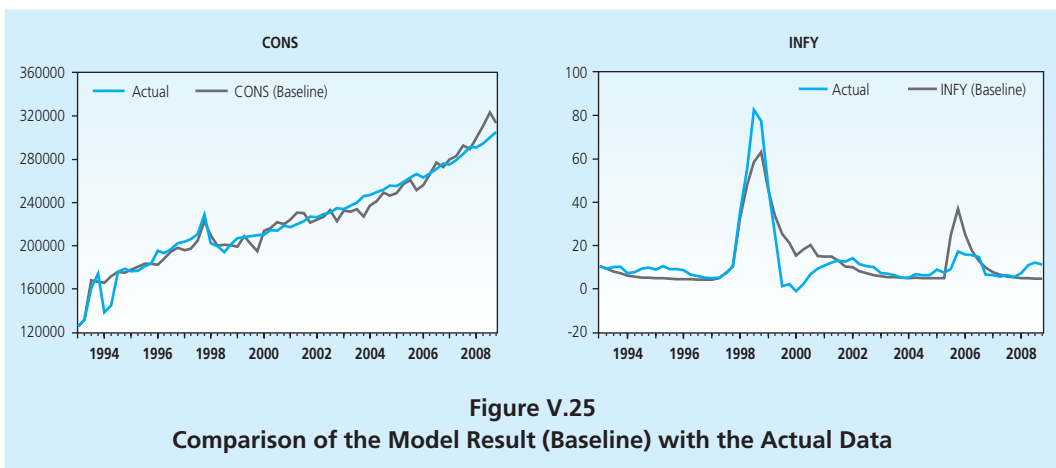
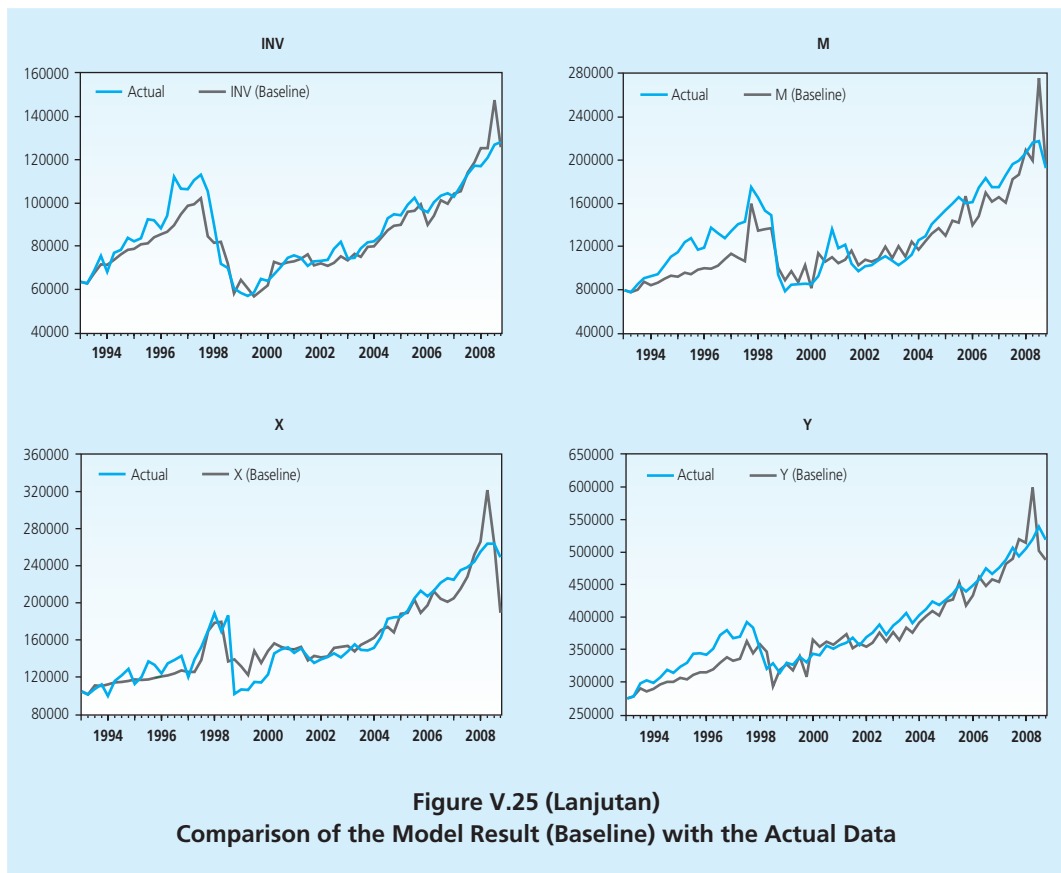

Figure V.25
Comparison of the Model Result (Baseline) with the Actual Data

⁷ Sensitivity testing on each parameter is not conducted.



IV.6. Simulation

In the next stage, the simulation conducted in this study is in order to find out the impacts of exchange rate depreciation, the change of world economic growth, represented by US, and the change of world goods price, represented by US as well.

Simulation of Exchange Rate

In this simulation, the exchange rate is divided into three scenarios of the Rupiah exchange rate to US depreciation within different percentage of depreciation. The simulation result shows that depreciation Rupiah exchange rate of 13.5% becomes Rp11,000 Rupiah per US dollar, whereas the consumption and investment are relatively maintained. This also occurs if the exchange rate is depreciated up to 18.6% and 23.8% becomes respectively Rp11,500/USD and Rp12,000/USD. This may be because the influence of exchange rate does not indirectly impact the consumption and investment.

Table V.11 Simulation of Exchange Rate						
Scenario 1: Depreciated Exchange Rate of 13.5% to be Rp 11.000/USD						
	Consumption	Inflation	Investment	Import	Export	GDP
Changes compared to baseline	Relatively Constant	Increase 0.1	Relatively Constant	Decrease -0.52%	Increase 0.45%	Increase 0.44%
Scenario 2: Depreciated Exchange Rate of 18.6% to be Rp 11.500/USD						
	Consumption	Inflation	Investment	Import	Export	GDP
Changes compared to baseline	Relatively Constant	Increase 0.1	Relatively Constant	Decrease -0.93%	Increase 0.82%	Increase 0.79%
Scenario 3 : Depreciated Exchange Rate of 23.8% to be Rp 12.000/USD						
	Consumption	Inflation	Investment	Import	Export	GDP
Changes compared to baseline	Relatively Constant	Increase 0.1	Relatively Constant	Decrease -1.32%	Increase 1.18%	Increase 1.13%

Meanwhile, the national export and GDPs increase along with the increased percentage of exchange rate depreciation (Table V.11), where the increase proportions of export and GDP are relatively the same. On the other hand, the national inflation experiencing the depreciation impact increases also, even though relatively small of 0.1. When the exchange rate depreciation is Rp11.0000/USD up to Rp12.000/USD, the inflation increase is maintained, which is 0.1. This result proves that the effect of depreciation of Rupiah exchange rate to inflation is relatively small.

Contrary, the import performance decreases due to the exchange rate depreciation, where the decrease rises when the proportion of exchange rate depreciation rises. This is because the high price of import goods when it is converted to Rupiah. This condition also indicates that the import is more on consumption goods, whereas the export is more on natural resources, not manufacturing production goods. Therefore, the increase or decrease of export will not always followed by the increase or decrease of import.

Regionally, several simulation results within the exchange rate depreciation of Rupiah to US Dollar from 1 USD = Rp11,000 up to 1 USD = Rp12,000 shows that the effect of depreciation of every region is relatively the same. It is noted that the decrease of exchange rate impacts the decrease of GDRP and consumption, but it is not in West Sumatera that has contrary impact. Meanwhile, the impact of Rupiah depreciation to US Dollar is seen from the decreased investment and import decrease of four provinces (Table V.12). The export increases in accordance with the decrease of exchange rate, except for Central Java Province, which is relatively maintained. So as the inflation impact of other three provinces that shows an inflation increase. Nevertheless, it decreases in Central Java.

Table V.12
Simulation of Regional Exchange Rate

Variable Change	West Sumatera (Rp11,000/USD)	West Java (Rp11,000/USD)	Central Java (Rp11,000/USD)	East Java (Rp12,000/USD)
GRDP	Increase 0.17%	Decrease 0.88%	Decrease 0.75%	Decrease 3.89%
Consumption	Increase 0.05%	Decrease 0.72%	Decrease 0.51%	Decrease 9.33%
Investment	Decrease 0.33%	Decrease 1.83%	Decrease 5.23%	Decrease 9.87%
Export	Increase 0.50%	Increase 2.1%	Constant Relatively	Increase 40.08%
Import	Decrease 0.31%	Decrease 4.24%	Decrease 1.13%	Decrease 60.3%
Inflation	Increase 1.21%	Increase 1.77%	Decrease 5.97%	Increase 1.54%

Source: Study result of Each KBI

Simulation of the World Economic Delay

The direct impact of the global financial crisis is the decrease of the world economic growth, particularly in US and several countries in Europe. Moreover, it is estimated that there will be a negative growth in 2009. To see the impact of the world economic growth delay, the scenario of US GDP growth delay is constructed and divided into three scenarios, namely 0.5%, 0.1% and -1%.

Table V.13
Simulasi Penurunan GDP US

Scenario 1: U.S. GDP growth decrease from 1.28% to 0,5%						
	Consumption	Inflation	Investment	Import	Export	GDP
Changes compared to baseline	Relatively Constant	Relatively Constant	Relatively Constant	Decrease -0.25%	Decrease -0.62%	Decrease -0.2%
Scenario 2: U.S. GDP growth decrease from 1,28% to 0.1%						
	Consumption	Inflation	Investment	Import	Export	GDP
Changes compared to baseline	Relatively Constant	Relatively Constant	Relatively Constant	Decrease -0.39%	Decrease -0.9%	Decrease -0.28%
Scenario 3 : U.S. GDP growth decrease from 1.28% to -1%						
	Consumption	Inflation	Investment	Import	Export	GDP
Changes compared to baseline	Relatively Constant	Relatively Constant	Relatively Constant	Decrease -0.98%	Decrease -1.86%	Decrease -0.52%

Table 1V.3 shows the simulation result of US GDP, which decreases from 1.28% to 0.5% and impacts the decrease of export and import, and GDP. Meanwhile, the other macro variables, such as real consumption, real investment and inflation are relatively maintained. When the simulation is continued to the US economic growth condition, it more decreases,

from 0.1% to minus 1.0%, whereas the export and import more decreases as well. This is also followed by the more decrease of the national economy, which is marked by the decrease of GDP.

Moreover, the result of simulation in West Sumatera and North Sulawesi by using China economic scenario experiences a decreased growth, which in fact impacts the delay of both provinces. The same result is also found in North Sumatera and South Kalimantan that also having the impact of Japanese economic decrease, in which the simulation result of Japanese GDP decrease lowers the GDRP of both provinces. Meanwhile, the US economic decrease, as the consequence of financial global crisis, influences South Sumatera, West Java, and Central Java (Table V.14).

Variable Change	GDP Japan decrease (North Sumatera)	GDP China decrease (West Sumatera)	GDP USA decrease (South Sumatera)	GDP USA decrease (West Java)	GDP USA decrease (Central Java)	GDP Japan decrease (South Kalimantan)	GDP China decrease (North Sulawesi)
GRDP	Decrease 0.74%	Decrease 0.03%	Decrease 1.27%	Decrease 1.47%	Decrease 5.61%	Decrease 0.69%	Decrease 5.01%
Consumption	Decrease 0.18%	Decrease 0.01%	Decrease 0.77%	Decrease 1.21%	Decrease 3.82%	Constant Relatively	Constant Relatively
Investment	Decrease 9.20%	Decrease 0.004%	Decrease 0.22%	Decrease 1.36%	Decrease 4.03%	Decrease 0.64%	Constant Relatively
Export	Decrease 8.06%	Decrease 0.1%	Decrease 2.42%	Decrease 4.19%	Decrease 12.15%	Decrease 1.49%	Decrease 9.75%
Import	Decrease 25.25%	Decrease 0.04%	Decrease 1.03%	Decrease 4.24%	Decrease 8.27%	Decrease 0.65%	Constant Relatively
Inflation	-	Decrease 0.20%	Decrease 2.84%	Decrease 0.09%	Decrease 77.94%	Decrease 0.76%	Constant Relatively

Source: Study result of Each KBI

Simulation of the World CPI Change

To see the impact of global financial crisis, this study conducts the simulation of world CPI change as a measurement tool on the price change of goods and services in the world. The scenario used is: the USA CPI decreases from 0.1% to 0% and -1.0%. In addition, the simulation also uses the scenario of goods and service price increase in USA, which is measured in the form of US CPI increase from 0.1% to 1%.

The simulation results of the first two scenarios, namely the USA CPI decreases to be 0% and -1% to produce an increase of real import, which are 1.16% and 1.83%. The impact of import increase is caused by the decrease of US goods and services that leads to the increase of import demand. The higher decrease of foreign price, which in this case is represented by US CPI, the higher increase of real import, in which the real import increase is followed by the real output decrease. National GDP decreases 0.48% and 0.76%.

The third scenario is: USA CPI increasing to be 1% has different impact, namely the decrease of import value of 0.22% is followed by the real output increase of 0.09%. The high price of foreign goods will decrease the import demand that makes the import value reduces. This will be followed by the increase of real output, where the third scenario notes that the real GDP is 0.09%. If this is seen from the (increased/decreased) import change as a response to the (increased/decreased) foreign price change, there is a difference on the percentage of import response when it increases and decreases.

Table V.15 Simulation of USA CPI Change						
Scenario 1: USA CPI Change decrease from 0.1% to 0%						
	Consumption	Inflation	Investment	Import	Export	GDP
Changes compared to baseline	Relatively Constant	Relatively Constant	Relatively Constant	Decrease 1.16%	Relatively Constant	Decrease -0.48%
Scenario 2: USA CPI Change decrease from 0.1% to -1%						
	Consumption	Inflation	Investment	Import	Export	GDP
Changes compared to baseline	Relatively Constant	Relatively Constant	Relatively Constant	Decrease 1.83%	Relatively Constant	Decrease -0.76%
Scenario 3 : USA CPI Change decrease from 0.1% to 1%						
	Consumption	Inflation	Investment	Import	Export	GDP
Changes compared to baseline	Relatively Constant	Relatively Constant	Relatively Constant	Decrease -0.22%	Relatively Constant	Relatively 0.09%

When the price increases, the percentage of import decrease is in fact smaller than the percentage of import decrease when the price reduces. So, even though the price increases, import slightly decreases. This shows that Indonesia's import is more in the form of most needed goods, such as raw materials.

V. CONCLUSION AND SUGGESTION

Based on the study results obtained, it may be concluded that:

1. The global financial crisis impacts the national and regional economies through the trade line with foreign countries (export-import). The export performance, either national or regional, decreases at the end of 2008, which proves that the effect of the global financial crisis may be directly felt. The decrease of export performance gives direct impacts to the decrease of national and regional outputs. This may be seen from the slightly decreased growth of national and regional economies, compared to the initial estimate.

2. Meanwhile, the consumption is slightly decreased, but it still becomes the main encouraging part of economic growth. This occurs either in the national or regional level. The high number of population also plays role in keeping the consumption high in Indonesia. In addition, the consumption is mostly influenced by the domestic factor, such as disposable income, both national and regional levels.
3. Based on the result of the simultaneous study, consumption and investment are relatively maintained, but the exchange rate of Rupiah is depreciated to US dollar. Meanwhile, export and import directly responds to the change of exchange rate. Inflation increases when Rupiah is depreciated but with small increase since the pass-through effect of exchange rate to inflation is relatively small as well.
4. If the world economic delay occurred by simulating the US GDP decrease and the world goods price index change, which is represented by US CPI, then the domestic economy also gets the impact. In national scale, export and import directly responds to the change. This is caused by the decrease of the world economy, which causes the decrease of export demand. On the other hand, if the price of foreign goods decreases, the import demand will increase as well.

From the previous conclusion, essentially stating that the global financial crisis impacts the national and regional economies, where the impact is difficult to avoid. However, there are several suggestions from this study to minimize such impacts, namely:

1. Government can play its roles by increasing the government expenditure since it can encourage the output increase, considering that theoretically the government expenditure (G) plays direct role to the formulation of GDP. This also may be conducted by regional governments, which then may encourage regional economies.
2. In addition, government expenditures, either central or regional governments, should be in the form of activities that may create job opportunity, such as constructing road, bridge, and other infrastructure buildings to create job opportunities for the locals. This can also increase people's purchasing power and absorb job seekers who are unemployed as the consequence of efficiency conducted by several companies. Constructing infrastructures also can encourage investor's interest to invest.
3. The role of the Bank of Indonesia as the central bank may be in the form of the monetary policy exemption by decreasing BI rate, which is used as the reference of interest for banking. By the decrease of interest, including the credit interest, it is expected that consumption and investment may increase. This will encourage the economic wheel, where the high consumption will encourage the increased production of goods. Finally, the growing real sector will attract the investors' interest to increase their investments.

REFERENCES

- Ehrmann, Michael, L. Gambacorta, J. Martinez-Pages, P. Sevestre, and A. Worms, "Financial System and The Role of Banks in Monetary Policy Transmission in The Euro Area", Working Paper European Central Bank, December 2001.
- Enders, Walter, *Applied Econometric Time Series*, Wiley, 2004
- Friedman, Milton, *A Theory of the Consumption Function*, First Edition, Princeton University Press, 1957
- Gujarati, Damodar, *Basic Econometrics*, Fourth Edition, West Point Military Academy, 2003
- Hamilton, James D., *Time Series Analysis*, Princeton University Press, 1994
- Hallwood, C. Paul and MacDonald, Ronald, *International Money and Finance*, Third Edition, Blackwell Publishers Inc, 2000
- Mankiw, N. Gregory, *Macroeconomics*, Fifth Edition, Worth Publishers, 2003
- Mojon, B, "Financial Structure and the Interest Rate Line of ECB Monetary Policy", ECB Working Paper No. 40, 2000.
- Patterson, Kerry, *An Introduction to Applied Econometrics: A Time Series Approach*, First Edition, Palgrave, 2000
- Romer, David, *Advanced Macroeconomic*, Second Edition, McGraw-Hill, 2001, p.472.
- Stiroh, Kevin J., "Investment and Productivity Growth: a Survey from the Neoclassical and New Growth Perspectives", Study Publications Program Industri Canada, Occasional Paper Number 24, June 2000

This page is intentionally left blank